

FED. ROAD DIST. NO.	STATE	JOB PIECE NO.	FISCAL YEAR	SHEET NO.	TOTAL SHEETS
6	OKLA.				

DESCRIPTION	REVISIONS	DATE

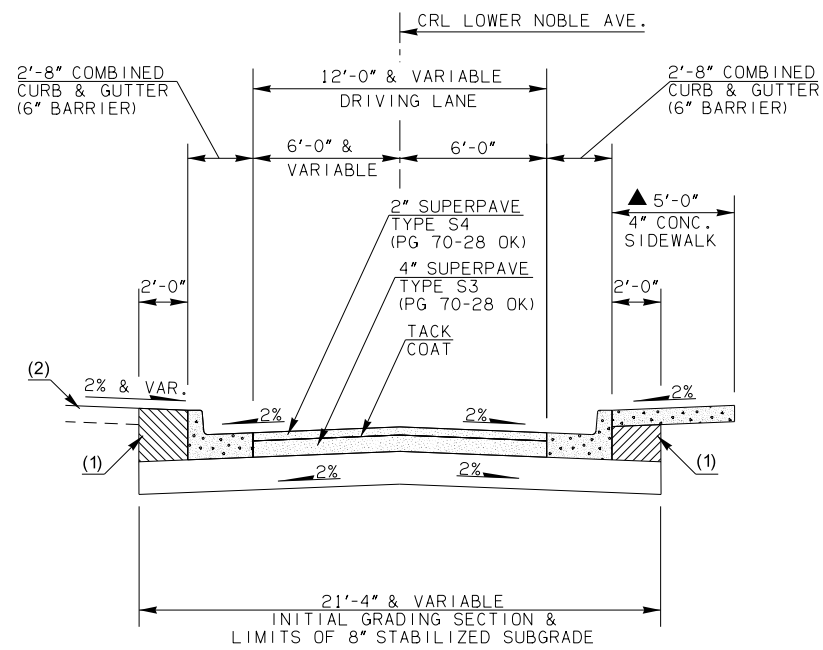

TYPICAL - LOWER NOBLE AVENUE
 STA. 0+00.00 TO STA. 2+50.00
 ▲ STA. 0+00.00 TO STA. 1+52.65

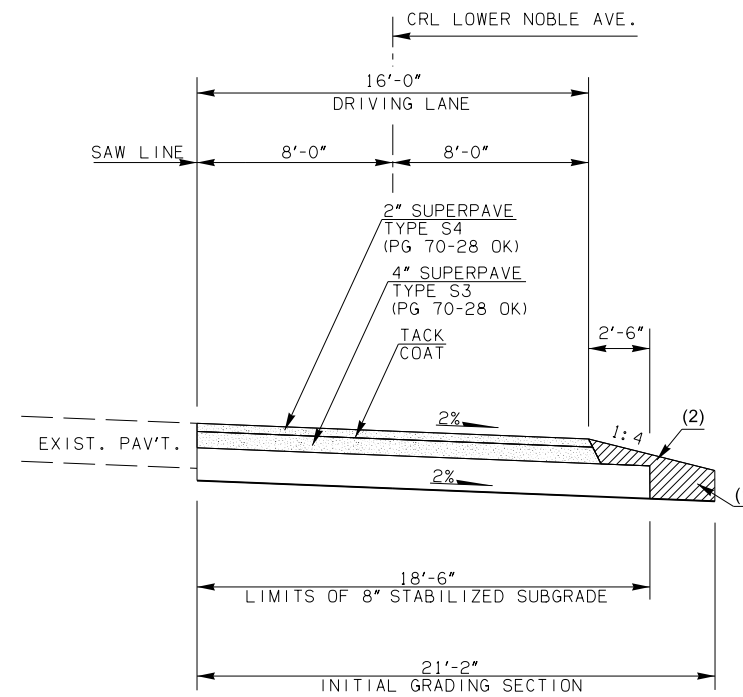

TYPICAL - LOWER NOBLE AVENUE
 STA. 2+50.00 TO STA. 3+05.00

(1) BACKFILL NOTE:
 TO BE BACKFILLED AND COMPACTED AS PART OF THE FINISHING OPERATIONS.
 QUANTITY IS MEASURED IN UNCLASSIFIED BORROW.

(2) TOPSOIL NOTE:
 THE CONTRACTOR SHALL STRIP ALL OF THE AVAILABLE TOPSOIL, STOCKPILE IT, AND PLACE IT BACK ON THE SECTION IN ACCORDANCE WITH SECTION 205 OF THE STANDARD SPECIFICATIONS. RESERVED TOPSOIL SHALL BE SPREAD FIRST ON THE COMPLETED SLOPES OF THE CUT SECTIONS AND THE REMAINDER ON COMPLETED FILL SLOPES OR OTHER PRIORITY AREAS LOCATED BY THE ENGINEER. ALL ADDITIONAL COSTS ASSOCIATED WITH OPERATIONS SHALL BE INCLUDED IN THE PAY ITEM FOR SALVAGED TOPSOIL, LUMP SUM.

THE GRADING LINE AS SHOWN ON THE TYPICAL AND CROSS SECTIONS IS TO THE TOP OF THE TOPSOIL. EARTHWORK QUANTITIES WERE NOT ADJUSTED FOR SALVAGE AND THE TOPSOIL QUANTITY IS INCLUDED IN THE MASS LINE BALANCE.

DESIGN	LL	
DRAWN	MRB	6/16
CHECKED		
APPROVED		
SQUAD	GREEN	

OKLAHOMA DEPARTMENT OF TRANSPORTATION
 ROADWAY DESIGN DIVISION

TYPICAL SECTION

STATE JOB NO. 21860(04) SHEET NO. 0008